

# Carolina Growler, Inc. Huntmaster Hunting Unit

Operator's Manual



This Manual contains information about the operation and upkeep of the  
Huntmaster Hunting Unit.

Manufactured by Carolina Growler, Inc  
under License from  
New Heights Manufacturing, Inc.

## Table of Contents

SAFETY PRECAUTIONS .....	1
I. INTRODUCTION.....	2
About This Manual.....	2
How to Obtain Service.....	2
II. SPECIFICATIONS.....	3
III. OPERATION.....	4
General.....	4
Pre-Operation Checks.....	4
Hunting Compartment Components.....	5
Set-Up.....	5
Operation.....	8
Breakdown and Transport.....	10
Troubleshooting.....	12
IV. MAINTENANCE.....	13
General.....	13
Periodic Maintenance Schedule.....	13
General Inspection.....	14
Lubrication System.....	14
Battery Care.....	14
Hydraulic Maintenance.....	14
Illustrations.....	15

## SAFETY PRECAUTIONS

Before operating Huntmaster, read the Operator's Manual and become familiar with it and your equipment. Safe and efficient operation can be achieved only if the equipment is properly operated and maintained. Many accidents are caused by failure to follow fundamental safety rules.

The following symbols found throughout this manual alert you to potentially dangerous conditions to the operator, service personnel or the equipment. Review each symbol and be familiar with what each one represents.

**DANGER**

This symbol warns of immediate hazards which will result in severe personal injury or death.



**WARNING!**

This symbol refers to a hazard or unsafe practice which can result in severe personal injury or death.

**CAUTION**

This symbol refers to a hazard or unsafe practice which can result in personal injury, product damage or property damage.

Electrical equipment, batteries, battery gases, exhaust fumes from fuels, heaters and moving parts present potential hazards that could result in serious, personal injury. Take care in following these recommended procedures.

**FUEL AND FUMES ARE FLAMMABLE!** Fire and explosions can result from improper practices.

- DO NOT SMOKE while servicing batteries. Lead acid batteries emit a highly explosive hydrogen gas that can be ignited by electrical arcing or by smoking.

**MOVING PARTS CAN CAUSE SEVERE PERSONAL INJURY OR DEATH**

- Keep hands away from any moving parts or pinch points.
- Before descending, check to make sure nothing is in the way of the hunting compartment descent path.

**GENERAL SAFETY PRECAUTIONS**

- Do not work on this equipment when mentally or physically fatigued, or after consuming alcohol or drugs that make the operation of equipment unsafe.

## SECTION I. INTRODUCTION

### ABOUT THIS MANUAL

This manual provides information about operating and maintaining the Huntmaster Hunting Unit. Study the manual carefully and comply with all the warnings and cautions. Deploying the unit properly and following the recommended maintenance will result in better performance, longer life and safer operation. All diagrams referred to may be found in the appendixes at the back of this manual.

### HOW TO OBTAIN SERVICE

When your Huntmaster unit requires service, contact the Carolina Growler, Inc. factory service department for assistance. Factory trained representatives are prepared to meet your service needs. Please call 1-(910)428-2439 for assistance.

When contacting Carolina Growler, Inc. with service questions, please supply the VIN number listed on the nameplate (figure 1).



**WARNING!**

Incorrect service or replacement of parts can result in severe personal injury, death and/or equipment damage. Service personnel must be qualified to perform service.

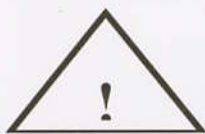

**WARNING!**

Do not attempt to deploy, use or operate any part of this unit until you have thoroughly read this operator's manual. Anyone failing to comply with this directive may incur severe injuries.

**CAUTION**

Carolina Growler, Inc. is not responsible for injury or damage resulting from non-standard equipment installations or modifications added to the unit by anyone other than Carolina Growler, Inc. factory authorized personnel.

## SECTION II. SPECIFICATIONS

TABLE 2-1. HUNTMASTER TROPHY AND CLASSIC SPECIFICATIONS

DESCRIPTION	SPECIFICATIONS
<b>MATERIALS</b> TRAILER FRAME COMPARTMENT: FRAME SIDES TOP	TUBULAR STEEL TUBULAR STEEL STEEL SHEET STEEL SHEET
<b>DIMENSIONS</b> TRANSPORT LENGTH WIDTH HEIGHT SET-UP WIDTH (OUTRIGGERS EXTENDED) HEIGHT (SEATED EYE LEVEL) HUNTING COMPARTMENT INSIDE DIMENSIONS INSIDE HEIGHT STANDARD WEIGHT CAPACITY GROUND CLEARANCE (TRANSPORT) INSIDE TRAILER DIMENSIONS WHEEL SIZE	21FT 7FT. 10IN. 8FT. 6IN.  14FT. 19FT.  72IN. X 72IN. 80IN. 750 LBS. 12 IN. 64IN. X 96IN. 225/75 R15
<b>WEIGHT</b> TONGUE WEIGHT OVERALL WEIGHT	350 LBS. 4260 LBS.
<b>ELECTRICAL</b> D/C VOLTAGE	12 VOLT
<b>HYDRAULIC SYSTEM</b> CYLINDER RATING HOSE RATING PUMP RATING (MAXIMUM PRESSURE)	3,000 PSI 4,000 PSI 3,000 PSI

## SECTION III. OPERATION

### GENERAL

Huntmaster is designed to elevate one to two persons (standard weight limit 750 lbs.) from ground level to an eye-level height of approximately twenty feet. This section covers the set-up, transport, and operation of the unit. It is recommended that the operator be completely familiar with the unit for safe operation.

### PRE-OPERATION CHECKS

Before operating the unit, check the ascent path of the compartment for overhead obstructions that could damage the unit or bring physical harm to the operator. Also, go through a brief inspection to make sure the unit is ready for operation.

**DANGER**

Do not deploy this unit under power lines, electrical, or communications wires. Note the ascent path of the compartment in illustration (figure 3). Unit may come in contact with electrical wires or other obstructions during ascent. Failure to comply with this directive may result in injury to personnel and damage to the unit.



**WARNING!**

Do not deploy the unit on sloping or uneven terrain. Failure to comply with this directive may result in injury to personnel and damage to the unit.



**WARNING!**

Do not deploy this unit in water. If wet or rainy conditions persist, proper assessment of ground conditions must be made before deployment. Soft or unstable ground may not provide sufficient load bearing capacity.

#### **Ascent Path**

Note that the compartment does not follow a straight up and down ascent path. When checking for overhead obstructions, keep the ascent path in mind. Make sure that the unit is not set up within 50 feet of any electrical lines.

#### **Inspection**

Give the entire unit a visual inspection for loose parts, severed cables, and oil leaks. Repair any problems before operating the unit.

sb

## HUNTING COMPARTMENT COMPONENTS

**Battery Switch:** This switch allows the operator to disconnect the battery during non-use to save battery charge. Quarter turn of knob disconnect battery to prevent drain.

**Up/Down Momentary Switch:** The operator may control the unit's elevation and descent from the hunting compartment. Depressing the "up" button raises the compartment until pressure is released from the button. Depressing the "down" button lowers the unit until pressure is released from the button.

NOTE: Huntmaster comes with an additional ground level control in the hydraulic pump compartment. To lift the hunting compartment, push the up button. To lower the compartment, push the down button.

**12 Volt Deep Cycle Battery:** Huntmaster comes equipped with a maintenance free battery.

## SET-UP

This section describes the components and steps involved in preparing the unit for operation. Some components may vary according to the model. Review each of the descriptions that apply and become familiar with their location and function. Refer to figures 2 and 4 for typical components used in set-up. The following sections contain procedures for using these components in set-up.



**WARNING!**

Do not attempt to elevate the unit until all outriggers and adjustable stabilizers have been properly deployed. Failure to comply with this directive may result in injury to personnel or damage to the unit.



**WARNING!**

Make sure to block tires on both sides whenever deploying the unit. Make sure the tires are properly blocked before attempting to elevate unit. Failure to comply with this directive may result in injury to personnel or damage to the unit.



**WARNING!**

Make sure the unit is deployed on level surfaces. Avoid very soft or uneven terrain.

NOTICE! For maximum stability, the unit should be either fully elevated or lowered to ground level when deployed.

## Uncoupling from towing vehicle

This section describes the function and operation of the unit's hitch and tongue-mounted stabilizer. Refer to this section for directions on uncoupling the unit from a vehicle. It is recommended that you become familiar with this section before attempting to uncouple the unit. Failure to do so could result in personal injury or damage to the unit.

### DEFINITION OF TERMS

**Coupler:** Designed to secure the unit's tongue to the towing vehicle.

**Tongue Mounted Stabilizer:** Designed to lift the unit's tongue high enough for the split-ball coupler to clear the towing vehicle's towing ball. This stabilizer should not be used to level the unit, but deployed as an additional stabilizer after the unit has been leveled.

**Tail Light Hookup:** Links the unit's tail lights to the towing vehicle's tail lights, turn signals, and brake lights.

**Safety Chains:** As a safety measure during towing, these chains act as a backup in case the towing vehicle's hitch fails. These chains must be used whenever towing the unit.

## Procedures for uncoupling from towing vehicle

1. Block wheels on both sides.
2. Disconnect tow vehicle tail light hookup and remove safety chains.
3. Rotate the tongue stabilizer by pulling the pin and rotating the stabilizer with the other (release the spring loaded pin as you rotate the cylinder). The spring loaded pin will re-engage itself when the stabilizer is in the vertical position. Turn the stabilizer's handle clockwise until the plastic wheel touches the ground.
4. To release the hitch, first remove the coupler's safety pin. Then, lift up on the ball release latch.
5. Return to the tongue mounted stabilizer and rotate the handle clockwise until the ball coupler has been raised to the top of the towing ball.
6. Drive the towing vehicle away from the unit before proceeding to stabilize the unit.

## Stabilizing the unit

### DEFINITION OF TERMS

Refer to figures as needed.



**Outriggers:** Give the unit its stability and are necessary for safe deployment. Outriggers should be retracted into the trailer's frame until the unit is set up. During deployment, outriggers should be fully extended until they stop for maximum safety and stability.

**Stabilizer Jacks:** Secure the unit and help provide maximum safety and stability when properly deployed. The stabilizer jacks are to be mounted on the end of every outrigger.

**Holding Pins for Stabilizer Jacks:** Designed to secure the stabilizer jacks in the horizontal (transport) position or in the vertical (deployment) position.

**Manual Ground Control:** Designed to lift the compartment from the ground. This is used primarily for setting up the unit.

**Outrigger Pins:** Secure the outriggers during transport and deployment.

## Deployment Procedures

1. Make sure the wheels of the unit are blocked on both sides so that the unit is unhooked from any vehicle (see unhooking instructions).
2. Using the tongue mounted stabilizer, eye the unit level. Do this by turning the stabilizer's handle clockwise to lift the tongue and counterclockwise to lower the tongue.
3. After the unit has been eyed level, go to one of the back corners and remove the outrigger pins. Holding the stabilizer, pull the outrigger out until it stops. Rotate the outrigger in the direction of the compartment until it stops and reinsert the pins.
4. Holding the stabilizer in one hand, remove the holding pin, rotate the stabilizer to the vertical position and re-insert the pin. Turn the jack handle until the base of the stabilizer comes in contact with the ground (you will come back and tighten these later).
5. Proceed to the remaining three corners and repeat steps 3-4.
6. After all of the outrigger stabilizer jacks have been deployed in the vertical position, go back to each one and rotate the jack handle until the stabilizer bases are all in firm contact with the ground. Final leveling should be accomplished using the two way bubble type level indicator located on the trailer frame.



**WARNING!**

Do not attempt to elevate the hunting unit until all outriggers have been properly deployed.

## Preparing for Operation

1. Remove the outside ramp holding rod which secures the ramp to the lifting arms.
2. Find the manual control located in the battery and pump compartment and push the up button, raising the hunting compartment enough (see figures 5 & 6) so that the ramp can lie down on the trailer.
3. Remove the inside ramp holding rod and lay it down.
4. Lay the ramp down toward the tongue of the trailer and away from the hunting compartment.
5. Go to the manual control and push the down button (see figures 5 & 6). Wait until the bottom of the hunting compartment comes to rest against the ground. The hunting compartment is now ready to be entered.

## The Hunting Compartment

**Removing Chair:** To remove the chair, release the nylon strap securing the chair to the floor and roll the chair out, (Chair and nylon strap not included).

**Locking Door Handle:** To lock the door handle, insert the key and turn it clockwise to the three o'clock position.

**Unlocking Door Handle:** To unlock door handle, insert the key and turn it counterclockwise to the 12 o'clock position.

## OPERATION

This section describes the functions and operations associated with elevating the hunting compartment and operating the accessory features of the unit.



**WARNING!**

Do not attempt to enter or exit the hunting compartment when it is in the elevated position.



**WARNING!**

Do not attempt to elevate the hunting compartment until the door is securely closed and the safety chain is in place.



**WARNING!**

Do not attempt to open the hunting compartment door at anytime when the hunting compartment is elevated, regardless of height.



**WARNING!**

When the hunting compartment is elevated, regardless of height, do not lean out of the windows or extend head, arms, or legs outside the hunting compartment.



**WARNING!**

The unit is designed to be deployed with one to two persons in the hunting compartment.



**WARNING!**

The recommended weight limit in the hunting compartment is 750 lbs. Do not exceed it.



**WARNING!**

Use of any heating device in the hunting compartment that burns fossil fuel may cause a build up of carbon monoxide resulting in brain injury or death.



**WARNING!**

Do not attempt to move the unit while in the elevated position.



**WARNING!**

Do not throw or drop any object from the hunting compartment.

## **D/C POWER**

Lift Function: The push button control inside the hunting compartment controls the ascent and descent of the hunting compartment. Push the up button and hold until the compartment reaches the desired height.

NOTE: When the unit reaches maximum elevation, the compartment will stop, but the unit's fail-safe hydraulic system will continue to cycle until the up button is released. If the button is held down after the unit is at full height, the unit's deep cycle 12 volt battery will start to be drained and there could be damage to the pump.

To descend, push the down button until the hunting compartment reaches ground level. Then release the button and the compartment will stop.

NOTE: Battery life is vital to the operation of the unit. Therefore, Huntmaster Trophy comes equipped with a charging source for the 12 volt battery. The Trophy unit is equipped with a solar panel, which keeps the battery optimally charged when the unit is deployed in the sun. Additional charging will occasionally be needed.

The Huntmaster is also equipped with an emergency hydraulic release lever in case of battery or other electrical failure. To use the release lever simply push the lever forward (toward the door) and the hunting compartment will descend slowly to the ground.

## **PREPARATION FOR TRANSPORT**

This section refers to the steps involved in transporting Huntmaster. The coupler requires a standard 2 inch ball. The following section refers to the steps involved in preparing the unit for transport.

## TRANSPORT PREPARATION PROCEDURES

1. After making sure the compartment is closed and locked, go to the manual ground level control and push the up button, raising the compartment until the support arms are high enough for the ramp to stand vertical to the compartment.
2. Stand the ramp up and attach the ramp holding rod to the ramp extension and lower the compartment until the support arm brackets rest on top of the ramp.
3. Attach the outside ramp holding rod to the ramp extension and insert pin.
4. Go to one of the back corner outrigger stabilizers and rotate the stabilizer handle to pick up the jack base.
5. Pull out the holding pin, replace the stabilizer in the horizontal position to the mounting bracket located on the side of the trailer base, and re-insert the pin. Remove the outrigger pin, slide the outrigger all the way into the trailer frame and re-insert the outrigger pin.
6. Go to the other side and repeat steps 5-6.
7. Go to front corners and repeat steps 5-6 with the exception that the stabilizer will be left on the outrigger mounting bracket.
8. Use the tongue mounted stabilizer to adjust the height of the tongue for connecting to the towing vehicle.



### WARNING!

Do not attempt to move the unit with any person or additional equipment in the hunting compartment.

NOTE: Make sure safety chains and running lights are connected to the towing vehicle and the lights are functioning properly before attempting to tow the unit.

NOTE: When storing any equipment on the trailer, keep it secured and centered in front of the axle for best towing results. Do not put any additional equipment inside the hunting compartment because any additional weight behind the axle could cause the unit to become unbalanced and make towing difficult.

NOTE: Make sure all locking bolts are tightened before transport. This will prevent the outriggers from working their way out of the outrigger sleeves.

**TROUBLE SHOOTING CHECKLIST:**

<b>PROBLEM</b>	<b>PROBABLE CAUSE</b>	<b>SOLUTION</b>
Fails to ascend	1. Low battery power 2. Bad battery connection 3. Compartment overloaded	1. Check Battery charge 2. Clean and tighten battery connections 3. Reduce weight in compartment
Fails to descend	1. Low battery power 2. Bad battery connections	1. Use hydraulic level to descend 2. Check Battery charge 3. Clean and tighten battery connections
Difficulty in towing	1. Unit has not been correctly put in the transport position 2. Trailer Load has been improperly distributed	1. Review the "Preparation for Transport" section of the Owner's Manual 2. Check to make sure the Trailer Load has been distributed on or in front of the axle
Moaning and vibration (usually during ascent)	1. Unit has not been properly greased 2. Cylinder seal has dried out because of infrequent use	1. Refer to Periodic Maintenance Schedule 2. Spray penetrating oil where polished bore comes out of the sleeve

## SECTION IV. MAINTENANCE

### General

Establish and adhere to a definite schedule for maintenance and service. If the unit will be subjected to extreme operating conditions, consult Carolina Growler, Inc. factory service department and determine an appropriate maintenance schedule.

Keep an accurate log of all service and maintenance for warranty support.

Perform all maintenance at the number of operating hours indicated. Use the schedule to determine the maintenance required, and then refer to the following sections for the maintenance procedures.

TABLE 4-1. PERIODIC MAINTENANCE SCHEDULE

SERVICE THESE ITEMS	DAILY	MONTHLY	SEMI ANNUALLY	EVERY 5 YEARS
General Inspection	X 1			
Check Battery	X or when used			
Grease Fittings			X	
Check Trailer Wheel Bearings			X 2	
Change Battery				X 3

- 1- Check for any leaks of hydraulic oil and any drop in tire pressure. Make a note of any maintenance concerns and repair minor problems immediately.
- 2- Check trailer wheel bearings more frequently if you pull the unit more than 200 miles a week or if the wheels have been submerged in water or mud.
- 3- Battery life may be longer or shorter depending on the amount of use.

## **GENERAL INSPECTION**

Perform a general inspection each time before operating the unit. Check the unit for any hydraulic leaks, broken or loose parts, and any reduction in tire pressure. Examine the hoses and check for any hydraulic leaks. If any problems are found, make note of them and have them corrected immediately.

## **LUBRICATION SYSTEM**

The unit is equipped with four grease fittings on each side of the unit. The unit's grease fittings were greased prior to shipment, so the unit will not need to be lubricated until its recommended maintenance interval. Refer to figures 1-3 for the location of the grease fittings.

NOTE: Two of the grease fittings located in the end of each support arm can only be greased when the unit is in the fully extended position.

## **BATTERY CARE**

The battery is maintenance free. If the unit does not ascend or is very slow to ascend the battery charge should be checked and charged if required. Since the battery performs a vital function in the operation of the unit, it is important that the battery is fully charged.

## **HYDRAULIC MAINTENANCE**

If a problem occurs with the unit's hydraulic system, take note of the symptoms and contact the Carolina Growler, Inc. factory service department at 910-428-2439 to discuss the proper maintenance.

### **Adding Hydraulic Oil**

Figure 6 shows the location of the reservoir cap. Add oil only if the unit needs it; the New Heights Manufacturing, Inc. factory service department can determine this if the unit fails to ascend to full height. The pump uses Dextron II transmission fluid, which should be filled to within about an inch of the reservoir's top. To determine the correct oil level, check the reservoir when the hunting compartment is all the way to the ground. Adding too much oil will cause the reservoir to overflow when the cylinders are retracted.

NOTE: Avoid opening the hydraulic pump's oil reservoir unless the pump needs additional hydraulic oil. It is important to be absolutely sure that no soil or foreign matter enters the reservoir because small particles of soil or foreign matter can cause the pump's valve to stick.



## REFERENCE DRAWINGS

Figure 1

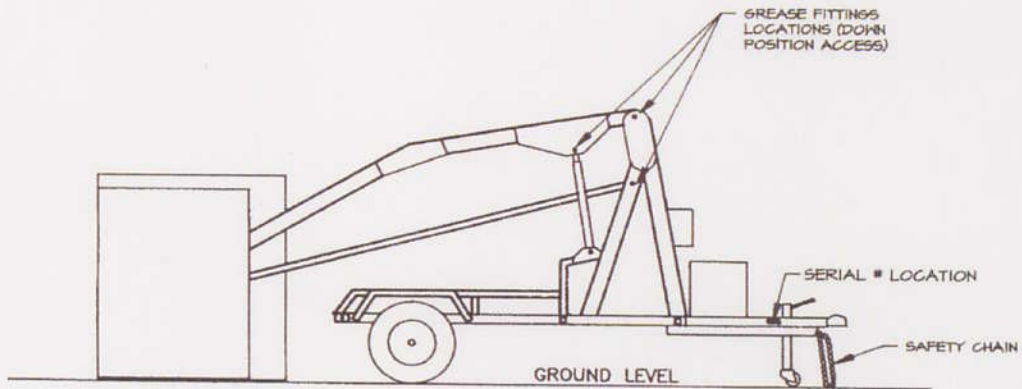

Figure 2

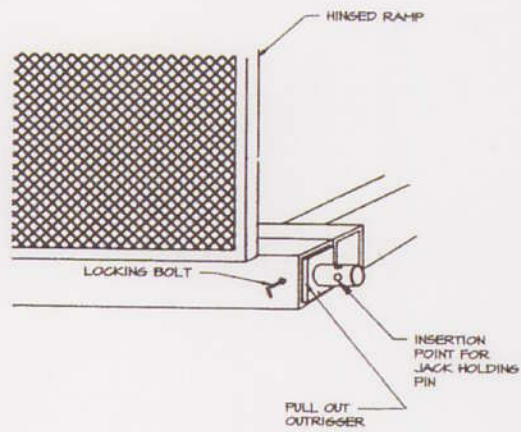

Figure 3

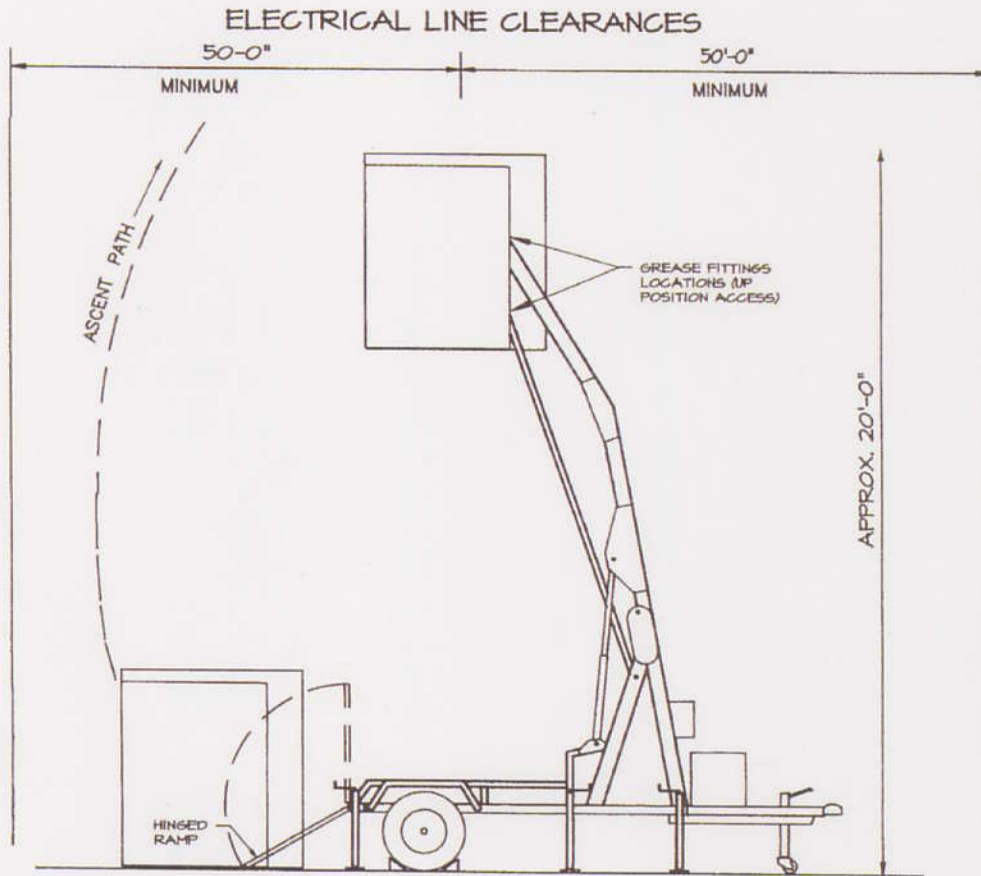
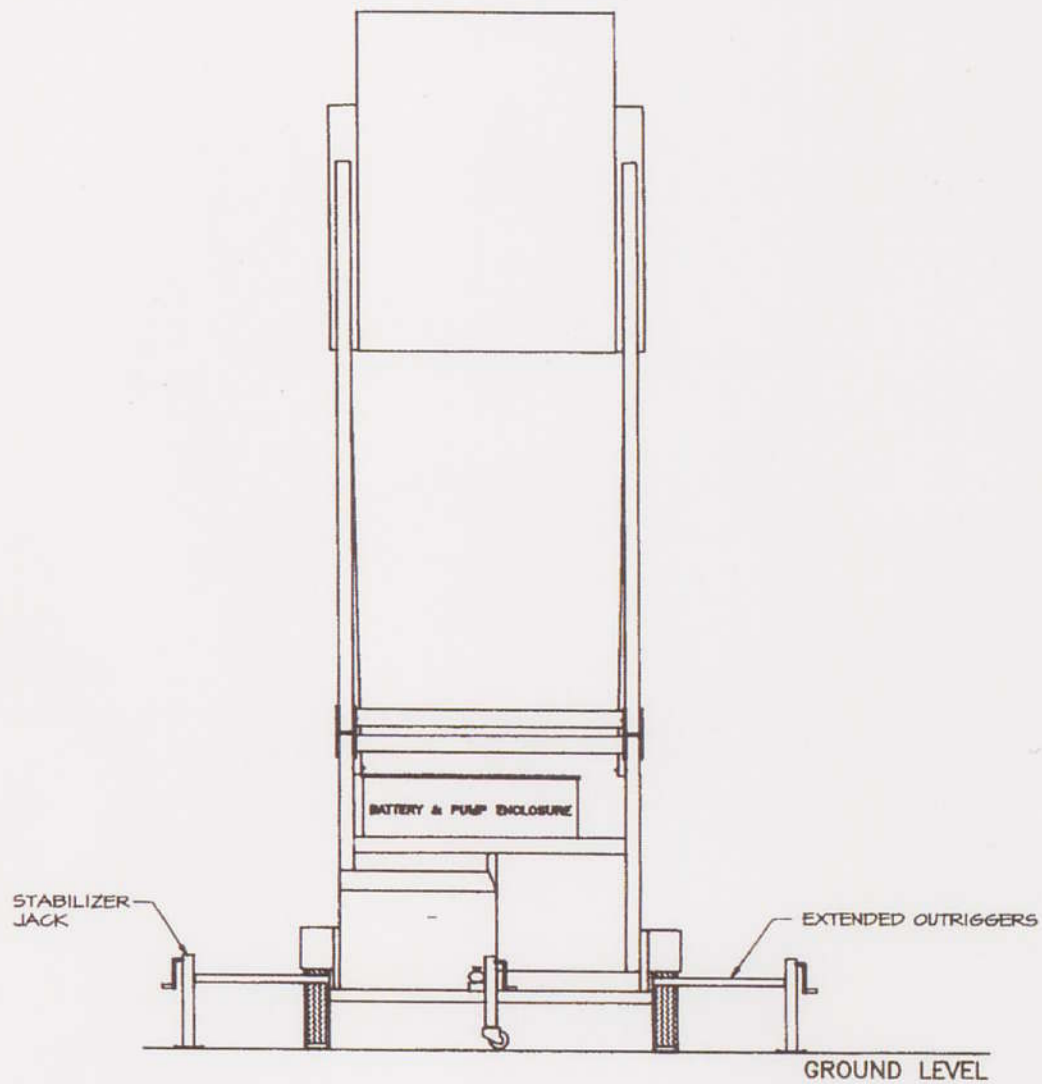

Figure 4



Carolina Growler, Inc.  
Huntmaster Hunting Unit  
Operator's Manual

